

SET UP FOR PRO-CLASSIC AND PRO-ULTLIGHT REPAIR STAND

FEATURES

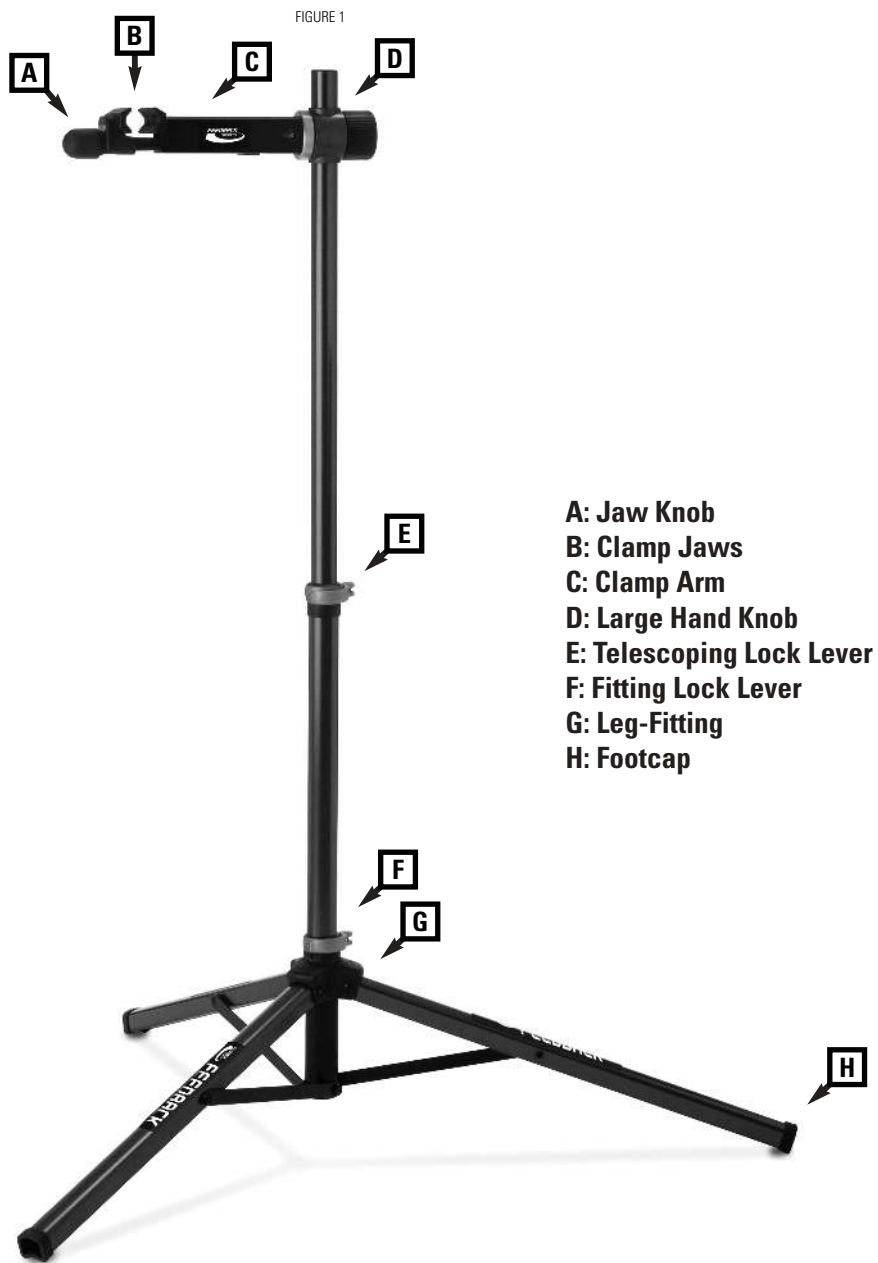

SET UP_UNFOLD THE STAND

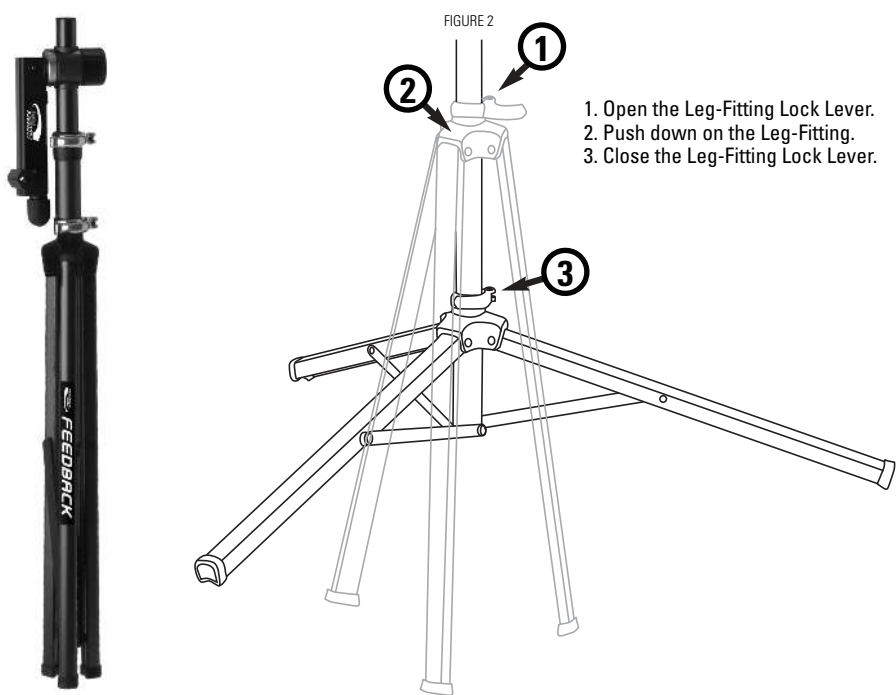

SET UP_UNFOLD THE CLAMP HEAD

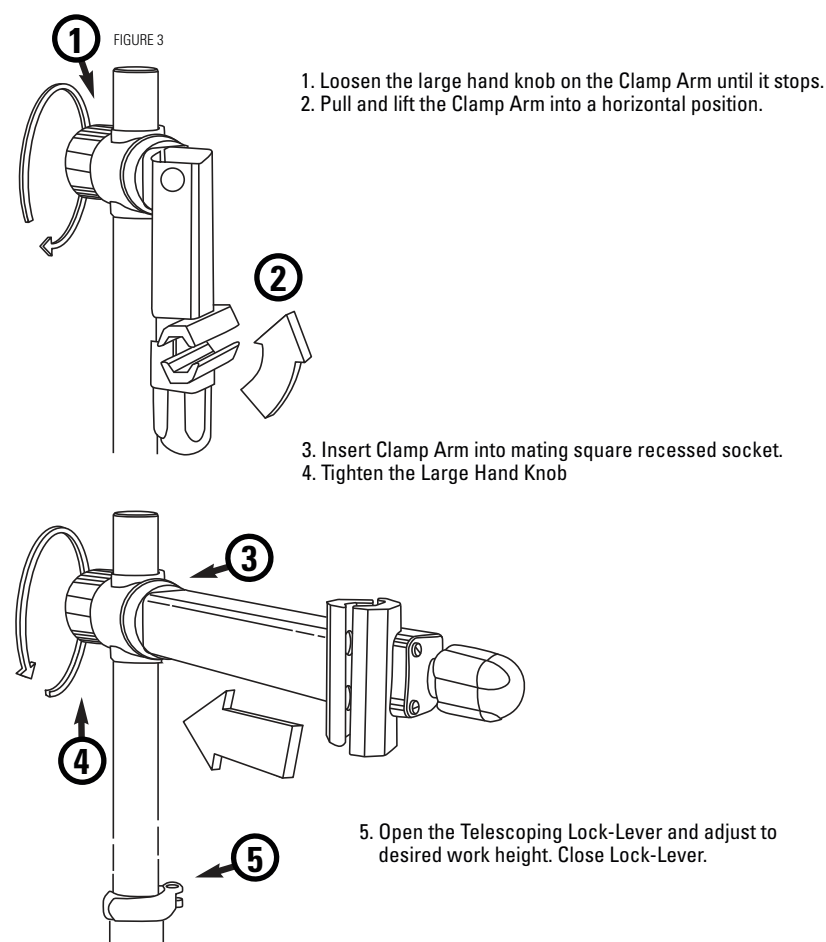

BICYCLE & THE STAND

PLACING BICYCLE IN THE STAND

1. Rotate the Jaw Knob counter-clockwise one half turn, pull outer Jaw open enough to accept the width of the seatpost.

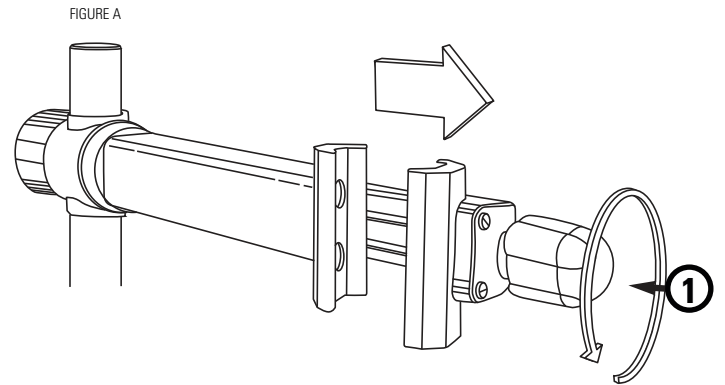

2. Lift and place seatpost into the clamp against the inner Jaw.
3. Push the Clamp Jaw firmly against seat post.
4. Rotate the Jaw Knob clockwise until bike is secure.

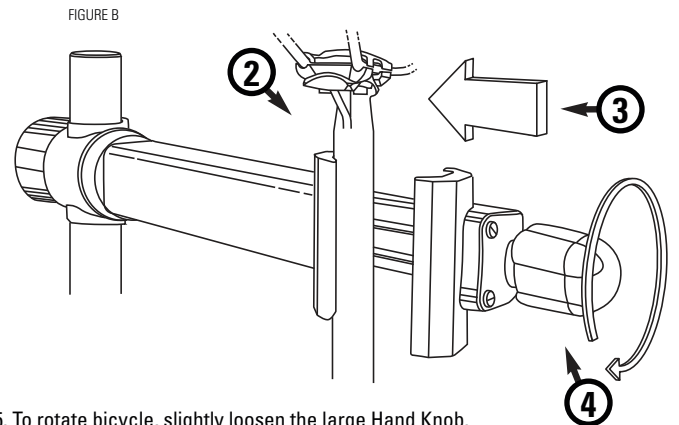

5. To rotate bicycle, slightly loosen the large Hand Knob.
6. Rotate bike to desired position and re-tighten. (will not harm the clutch mechanism to rotate under load)

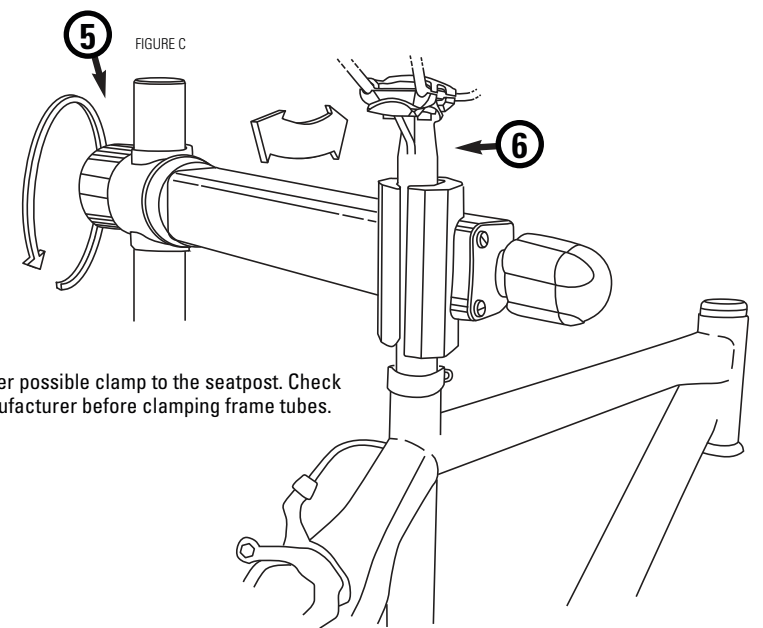

NOTE: Whenever possible clamp to the seatpost. Check with bicycle manufacturer before clamping frame tubes.

REMOVING BICYCLE FROM THE STAND

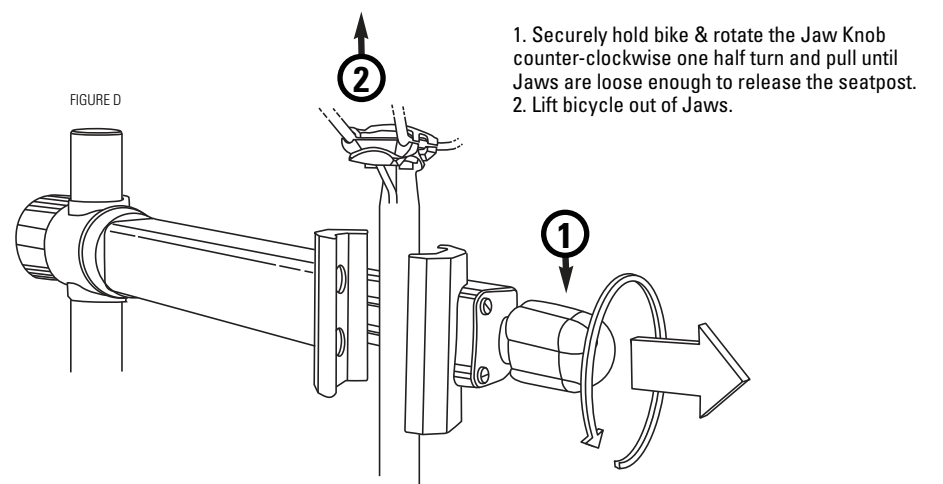

MAINTENANCE TIPS

> If excess clamp jaw friction is present, the threaded rod for the Secure-Lock jaw needs to be lubricated with a standard chain lube. To access, remove the innermost Clamp Jaw using a 4 mm or 5/32" Allen wrench and fully extend clamp. Apply lubricant to rod and replace jaw.

> Maximum grip on the bicycle is achieved when the jaws are free from any oil or dirt. Small amounts of any oil, including hand oil, can cause the jaws to under perform. When needed, clean jaws with alcohol or detergent a damp cloth.