

ASSEMBLY FOR 2 BIKE / SINGLE SIDED VELO STAND

STEP 1

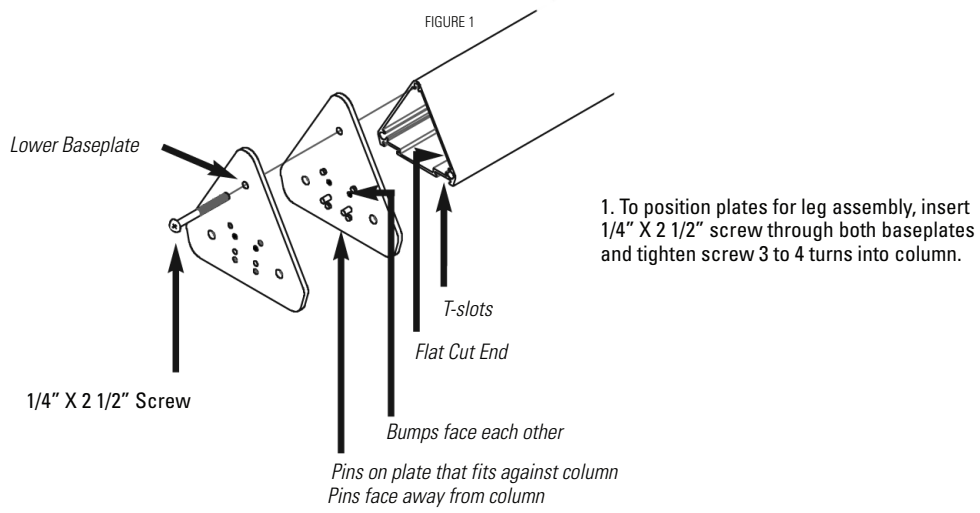

STEP 2

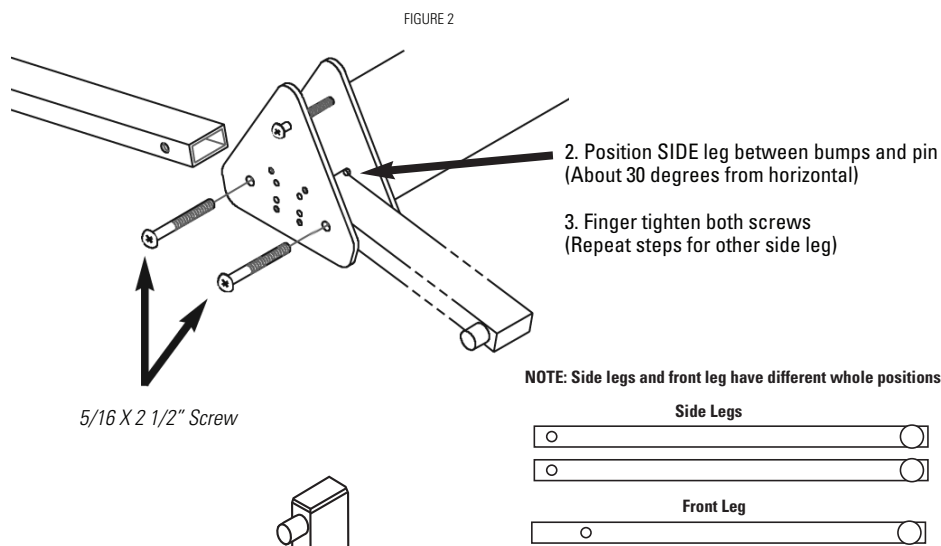

STEP 3

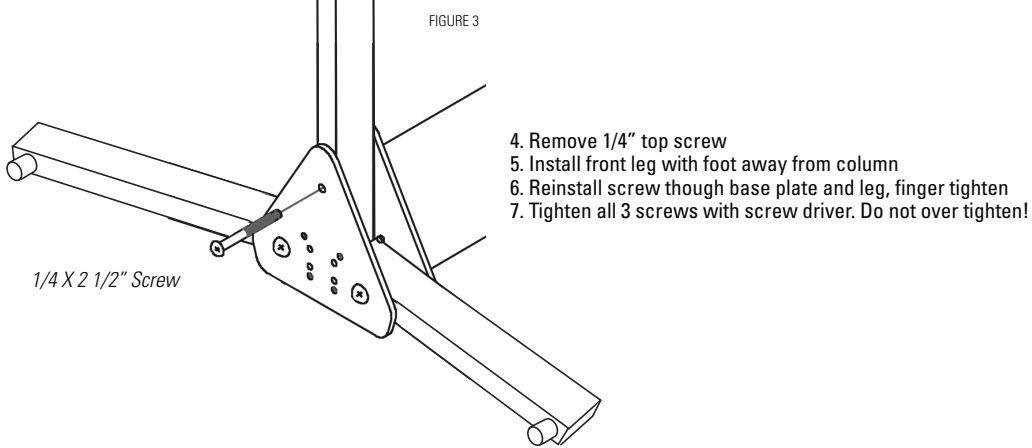

STEP 4

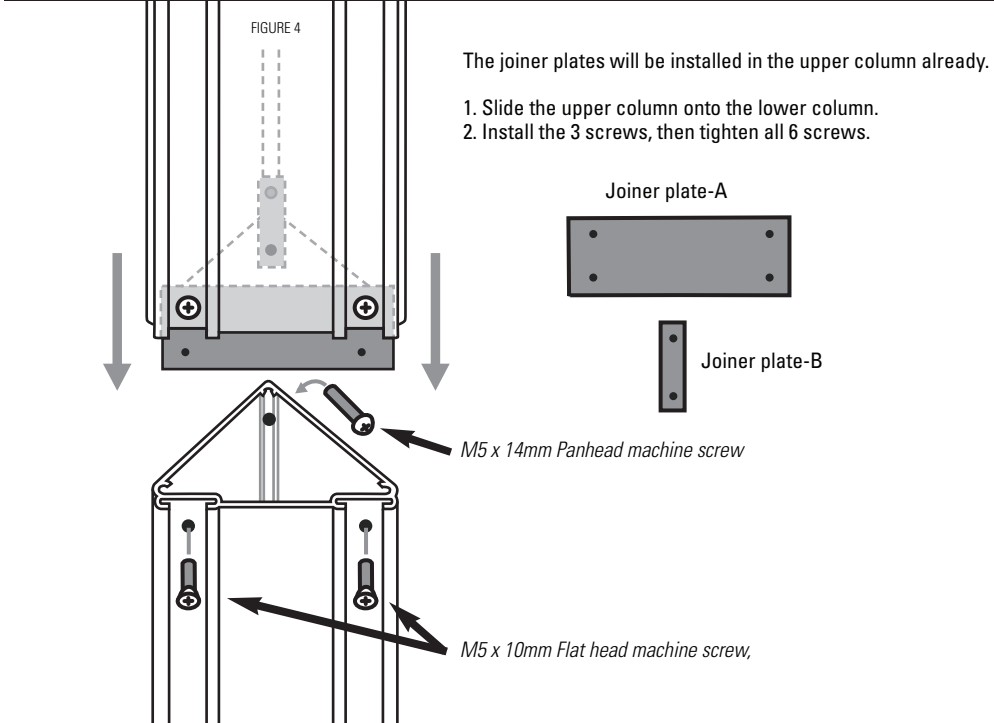

STEP 5

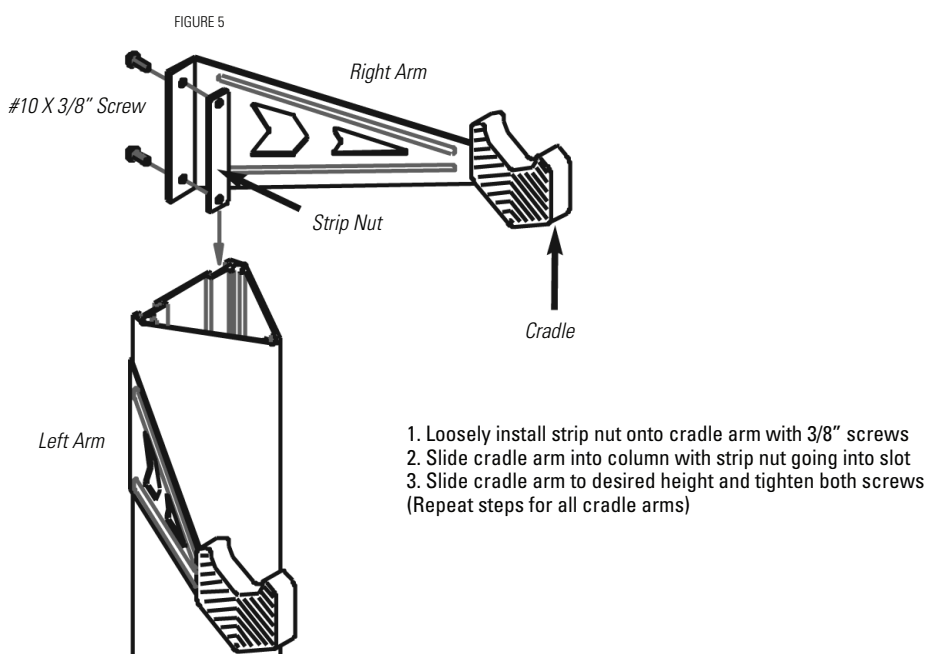

ASSEMBLY FOR 4 BIKE / DOUBLE SIDED VELO STAND

STEP 1

To expand the Velo Stand to hold 4 bikes, use the EXP-24 accessory product.

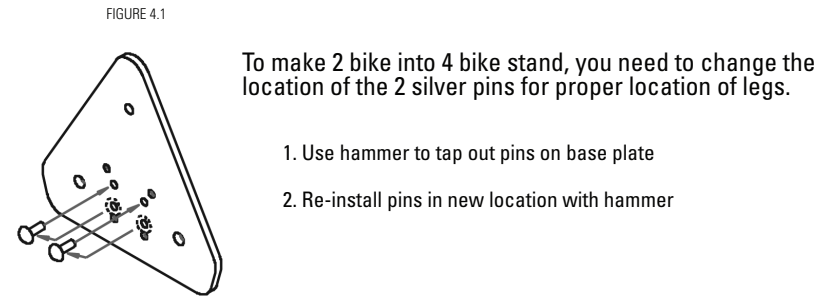

STEP 2

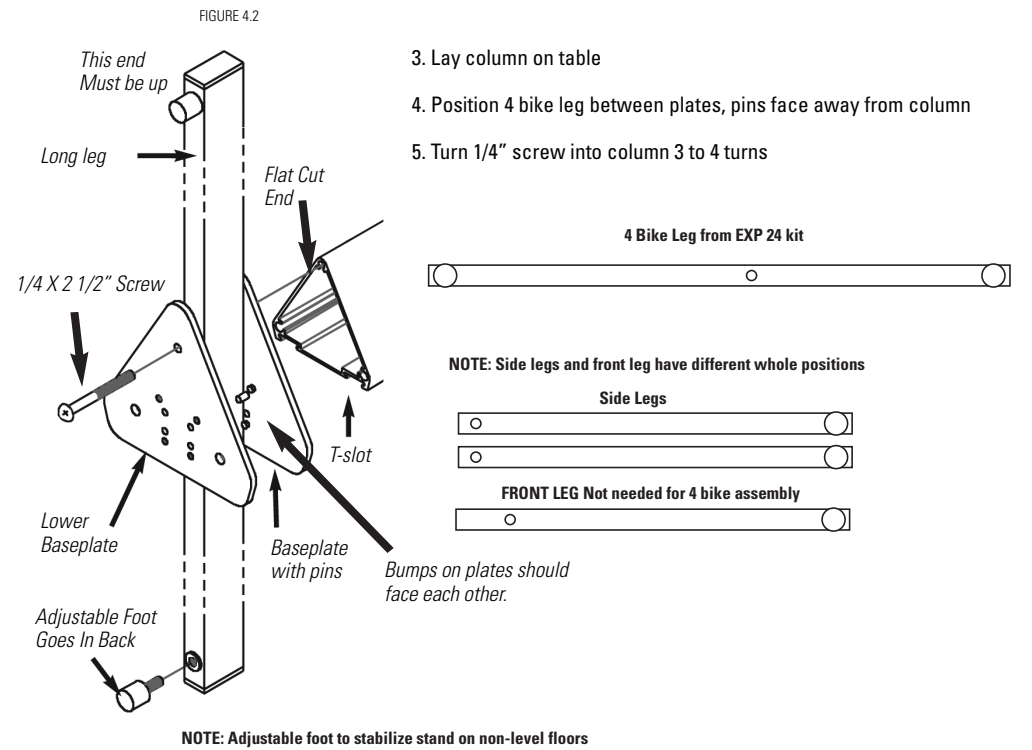

STEP 3

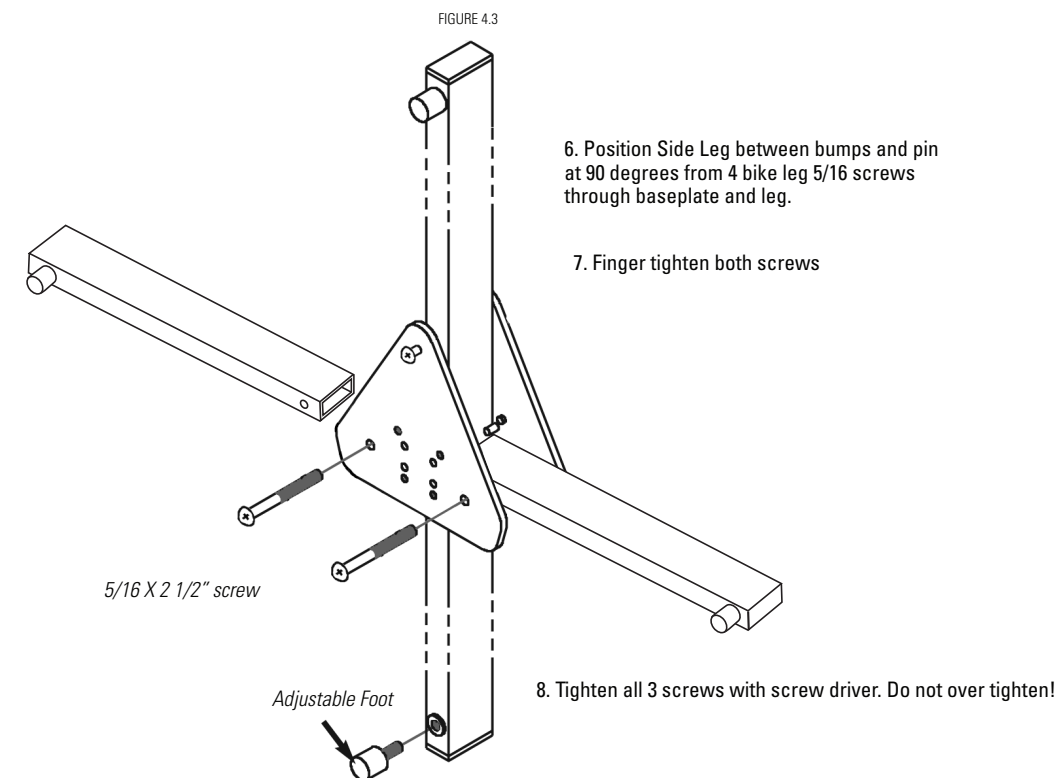

STEP 4

NOTE: You have two options for positioning cradle arms

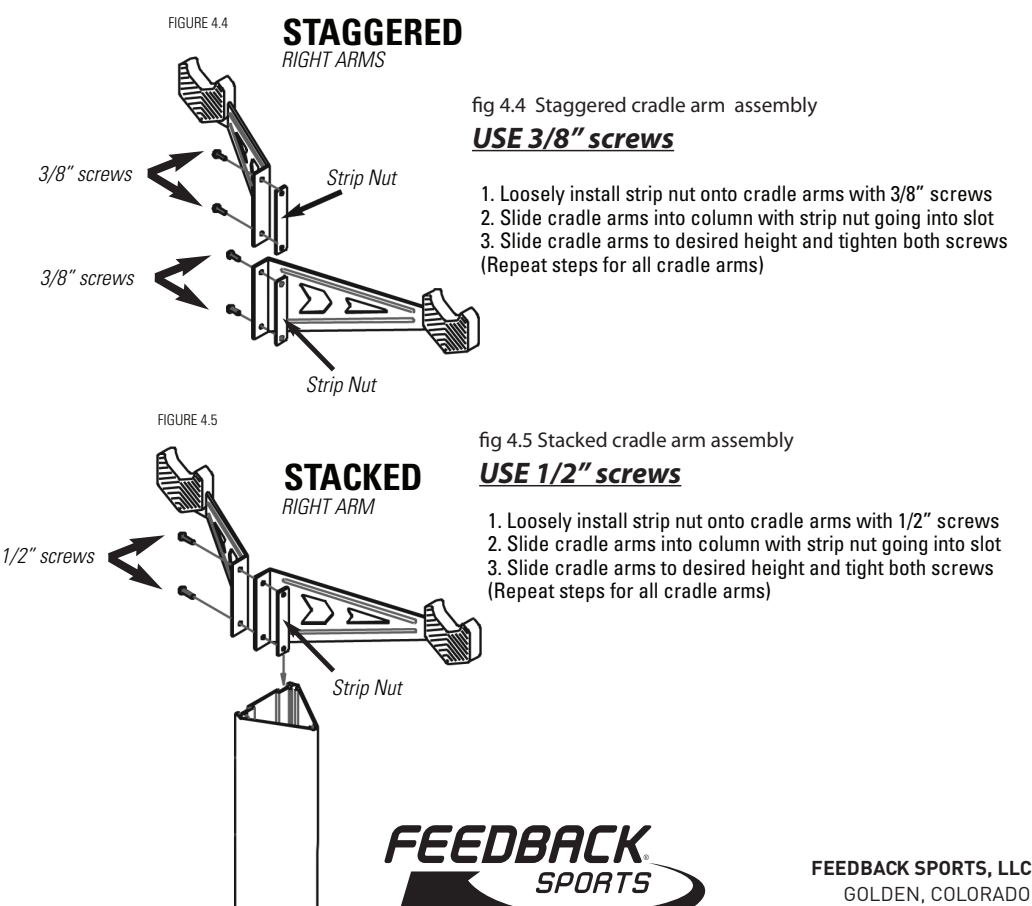

FEEDBACK SPORTS, LLC
GOLDEN, COLORADO
1(800) 975-2854
TechSupport@feedbacksports.com

WWW.FEEDBACKSPORTS.COM